

**MOMAC**

**LOVOL**

**LOVOL**

**LOVOL**

**LOVOL**

**FR560F**  
WPH

**EXCAVATOR**

**FR560F**



# FR560F EXCAVATOR

## SPECIFICATION

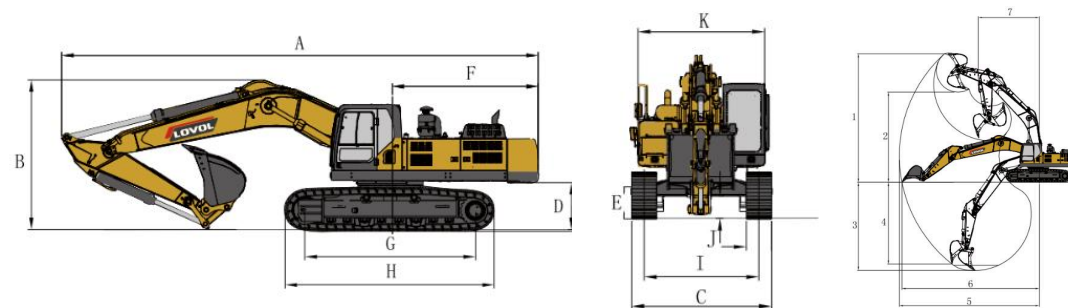

### DIMENSIONS

SHIPPING LENGTH	A	12205MM
BOOM HEIGHT	B	3907MM
SHIPPING WIDTH	C	3340MM
GROUND CLEARANCE OF COUNTER	D	1375MM
WEIGHTMIN. GROUND CLEARANCE	E	562MM
TAIL TURNING RADIUS	F	4020MM
LENGTH TO CENTER OF ROLLERS	G	4430MM
TRACK LENGTH	H	5500MM
TRACK GAUGE	I	2740MM
TRACK SHOE WIDTH	J	600MM
ROTARY PLATFORM WIDTH	K	3200MM

### OTHER SPECIFICATIONS

BOOM LENGTH	6900MM
ARM LENGTH	2900/2550MM
TRACK SECTION NUMBER(EACH SIDE)	50
TRACK ROLLER NUMBER	9

### WORKING RANGE

MAX. DIGGING HEIGHT	1	10812/10500MM
MAX. DUMPING HEIGHT	2	7345/7200MM
MAX. DIGGING DEPTH	3	7172/6815MM
MAX. VERTICAL DIGGING DEPTH	4	5256MM
MAX. DIGGING RADIUS	5	11544/11226MM
MAX. GROUND DIGGING RADIUS	6	11317/10991MM
MIN. TURNING RADIUS	7	4962MM

### ENGINE

ENGINE MODEL	WEICHAI WP14T
NUMBER OF CYLINDERS	6
MAX. TORQUE/SPEED	2900N·M/(1200-1500)RPM
DISPLACEMENT	13.5L

### HYDRAULIC SYSTEM

MAX. MAIN PUMP FLOW	423.5×2L/MIN
MAIN SAFETY VALVE PRESSURE	34.3MPA

### OIL CAPACITY

FUEL TANK	780L
HYDRAULIC TANK	350L
ENGINE OIL	40~52L

### MAIN PERFORMANCE

BUCKET DIGGING FORCE	320KN
ARM DIGGING FORCE	250KN
MAX. TRACTION FORCE	330KN
MAX. WALKING SPEED	5.5KM/H
MIN. WALKING SPEED	3.4KM/H
ROTARY SPEED	7.8R/MIN
GRADEABILITY	35°
GROUND PRESSURE	89KPA



# FR560F

Rated Power	562kW/1900rpm
Operating Weight	53000kg
Bucket Capacity	2.8 ~ 3.2m <sup>3</sup>

## FR560F EXCAVATOR

# KEY FEATURES

### PRODUCTIVITY

#### Superb Match

Each component in powertrain system, such as engine, gear, rotary motor, working pumps and hydraulic cylinder are specially customized to achieve perfect match with one another, the whole system features are more reliable.

#### Great Digging Force

On the premise of ensuring static digging force, LOVOL dedicate to research of dynamic digging force. The system will automatically detect the pressure when face big frustration during digging, and automatically adjust output pressure to keep the powerful force in digging process.

#### Larger Bucket

Equipped with larger bucket which is specially designed to achieve maximum productivity and durability. The unique shape design improves the bucket's stability when doing loading job. Applying with latest technology and optimal hydraulic system, it has good performance on fuel consumption.

### RELIABILITY

#### Advanced Technology

First-user of function-relief cushion valve system in industry, machine's respond could keep the same speed even in the extreme cold weather. On the premise of keeping the optimal impact pressure, the starting or switching of working device without any postpone, that makes smooth, efficient and energy-saving operation of machine and reaches to leading level of industry.

#### Powerful Engine

The new generation of WEICHAI WP13H engine originally imported from America which is specially designed for mining applications. Its exclusive PT fuel control and injection technology delivers higher precise and full efficient traits compared to traditional electric controlled high-pressure common rail technology.

#### Electric Control Positive Flow System

During the design stage, LOVOL has utilized the latest technologies to develop an integrated hydraulic system. The positive flow control system adjusts the displacement of pump and the motion of valve spool simultaneously, delivering optimal operating experience for the operator with smooth and responsive control.

# KEY FEATURES

## ROBUSTNESS

### Rigorous Test and Experiment

Machine test: LOVOL CL-6 machine testing yard covers more than 200,000 square meters, it can simulate various applications like earthmoving, aggregate, sand, quarry and forth. The test including strengthen vibration, noise, working efficiency, oil consumption, travel and climbing tests, etc. Every new model should go through more than 2,000 working hours strengthen combination test here.

### Robust Chassis

Reinforcement of Track Roller, Carrier Roller, Idler, Drive Roller and Track makes brace capacity increase dramatically which can also working in the temperature of -45°C. The crawl tracks are made of high-strength anti-wear steel, with great grip on ground.

### Reinforced Working Device

Adopts high-strength rock bucket teeth which is special suitable for the tough applications, the boom and arm are reinforced to prolong the service life. Self-lubrication shaft sleeve is used to make every linkage works smoothly with high durability.

## COMFORT

### Large Spacious Cab

Equipped with spacious cab which provides operator large space to operate machine. The premium suspension seat with armrests is very comfortable and it can reduce the working fatigue dramatically. Front windshield can be partially or fully retracted to the cab roof. Rearview camera is optional to get better rear vision in order to improve operation safety in jobsite.

### Ergonomic Design

The proportional joystick delivers sensitivity, accuracy and smoothness during operation. This joystick is specially designed to meet different operating conditions. Intelligent control system is standard which could control diverse attachments such as bucket, hammer, scarifier and hydraulic scissors.

### Low Noise and Low Vibration

In order to reduce work fatigue and improve productivity, the noise inside of cab has been controlled to the lowest level. The cab is attached to the frame with buffer that dampens vibrations and sound levels to enhance operator comfort.

## FR560F EXCAVATOR

# STANDARD CONFIGURATION

### ENGINE

- TURBOCHARGED, 6-CYLINDERS, WATER-COOLING, DIRECT INJECTION
- RADIATOR WITH PROTECTIVE FENCE
- OIL BATH TYPE CLEANER
- AIR INTAKE HEATER
- FAN GUARD
- DOUBLE FILTERS, DRY AIR FILTER
- ENGINE OIL PAN WITH OIL DRAIN VALVE
- AUTOMATIC IDLE SPEED SYSTEM
- THREE-STAGE FUEL FILTER
- 75A/24V ALTERNATOR

### CAB

- ASHTRAY
- CIGARETTE LIGHTER
- SEAT BELT
- SHADE PLATE
- STORAGE COMPARTMENT
- EMERGENCY HAMMER
- AIR CONDITIONER
- AUDIO SPEAKER
- SHOCK ABSORBER
- FLEXIBLE AERIAL
- RADIO
- HYDRAULIC SAFETY LOCKING ROD
- SUN PROOF SAFETY GLASS
- CAB FLOOR MAT
- PULL-UP FRONT WINDOW
- DISMOUNTABLE LOWER WINDSHIELD
- SUN SHADE WINDOW
- WINDSHIELD WIPER
- SKYLIGHT WINDOW
- SUSPENDED SEAT
- BIG STORAGE AREA

### CHASSIS

- FIXED CHASSIS
- 600MM DOUBLE TOOTH TRACK PLATE

### HYDRAULIC SYSTEM

- AUTOMATIC HYDRAULIC SYSTEM (FLOW CONFLUENCE SYSTEM)
- MULTISTAGE FILTRATION SYSTEM
- ANTI-SWAY VALVE
- BOOM AND STICK LOCKING VALVE
- CYLINDER BUFFER DEVICE
- ANTI-SLOPE TURNING DEVICE
- WASTE OIL DRAINAGE PIPELINE
- PILOT BUFFER VALVE (ROTARY, STICK, BOOM)
- DUAL-SPEED TRAVEL MOTOR
- HYDRAULIC HAMMER PIPELINE

### ELECTRONIC CONTROL SYSTEM

- 24V POWER BATTERY
- MONITOR BRIGHTNESS ADJUSTMENT
- MAINTENANCE TIPS
- SAFE STOP & START FUNCTION
- MASTER SWITCH
- ENGINE START PROTECTION
- MULTILINGUAL DISPLAY
- CAB CEILING LIGHT
- DIAGNOSTIC INTERFACE
- EMERGENCY STOP SWITCH
- AUTOMATIC DIAGNOSIS SYSTEM
- AUTOMATIC IDLE SPEED SYSTEM
- ONE-TOUCH PRESSURE ENHANCEMENT
- ANTI-THEFT SYSTEM

### SWING PLATFORM

- TOOLBOX
- LARGE PEDAL
- LARGE HANDRAIL
- BOTTOM GUARD PLATE
- ANTI-CRASH BEAMS
- ANTI-SKID PLATES
- PASSAGE WITH HANDRAILS

## FR560F EXCAVATOR

# CORE COMPONENTS

## INCREASE YOUR PRODUCTIVITY AND PROFIT WITH LOVOL ATTACHMENTS

You can easily expand the performance of your machine by utilizing any of the variety of LOVOL Attachments. Each LOVOL Attachments is designed to fit the weight and horsepower of LOVOL Excavator for improved performance, safety, and stability.

Hydraulic Hammer



Scarifier



Standard Bucket

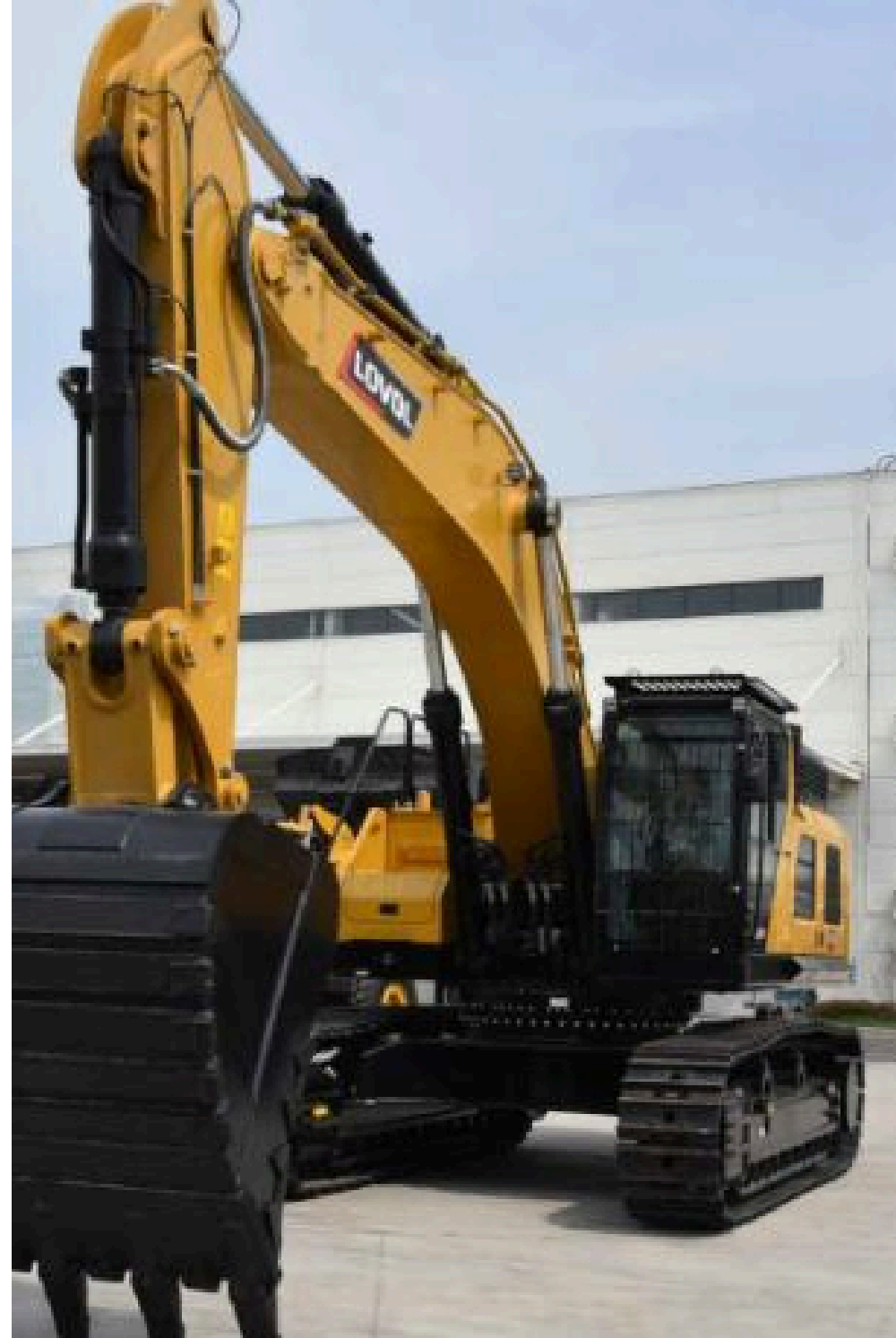

# MOMAC

# LOVOL

**MOMAC LOVOL**

[momaclovol.com](http://momaclovol.com)

**Al-Barghash Tower Prince Turkey Street Al Khobar Saudi Arabia**

As manufacturer, LOVOL has right to constantly upgrade and improve our products without informing to customers. The pictures in literatures are for reference only, the detailed specifications are subject to real products.

